



## **HFT-1500 Automated High Frequency Test System**

High Speed, High Accuracy Robotic Testing

The HFT-1500 automates the testing of high frequency Printed Wiring Boards (PWB). The system provides numerical data on circuit trace impedance, propagation delay, effective dielectric constant, and interconnect loss. The information gathered can be automatically evaluated against pass/fail criteria or used to grade the quality of PWBs.

### **Capabilities Summary**

- 1) Single-ended and differential controlled impedance testing on PWBs
- 2) Accurately measures impedance, propagation delay, propagation velocity, effective dielectric constant and interconnect loss.
- 3) Collects TDR Waveform files for off-line viewing.
- 4) Reporting of Impedance, Delay and Bandwidth for both sides of Differential pair
- 5) Test Software is compliant with IPC TM-650 2.5.5.7 Controlled Impedance Testing Standard
- 6) Test coupons, boards, and panels
- 7) Handles boards as small as 5.25" x 0.5" and panels up to 18" x 24"
- 8) Short changeover time from one type of board to another (<60 secs)
- 9) Manual probe change operation
- 10) Measurement repeatability of 0.05 $\Omega$  standard deviation
- 11) Flight Time measurement repeatability of 4 psec single standard deviation.
- 12) Accurately measure traces as short as 0.50"
- 13) Robotic system provides rotation of probe assembly to probe all test pad orientations
- 14) Built-in support for the Tektronix DSA8200, TDS8200, and TDS8000 TDR instrumentation
- 15) Capability for automatic measurement calibration and verification system with a 50 $\Omega$  airline
- 16) Ergonomic operator interface
- 17) System has an available ethernet port for SPC plant hook-up
- 18) Test Speed 1-5 seconds per test point
- 19) Flexible reporting package allows output to printer and many other formats (MSWord, Excel, html, etc.)
- 20) Extensive Test Report Generation (including Histograms and Out-of-Center reports)
- 21) Automatic CAD/CAM data importation
- 22) System is designed with a SMEMA interface for conveyer hook-up
- 23) Extremely robust probe
- 22) Data storage compatibility with Accu-Prober System
- 24) Verify Test Results Capability (select any test point for verification)
- 25) Operational Event Logging

## Hardware

### *Robot Assembly*

- 1) Four (4) axis robotic system, X,Y,Z, $\theta$
- 2) Working envelope: 600mm (23.6") x 450mm (17.7") with 360 degree rotation and extend/retract capability of 100mm (3.9")
- 3) Robot Speed: 65 inches/sec
- 4) Repeatability: +/-0.01mm (+/-0.0004")
- 5) Robot Mounting: Horizontal
- 6) System Payload: 5 lbs

### *Operators Station*

- 1) Flat panel monitor (Black)
- 2) Keyboard (Black)
- 3) Mouse (Black)
- 4) PC computer has a minimum of a Pentium processor, 1GB ram, 200 GB hard disc, 10/100/1000BaseT ethernet port, One serial ports, One parallel port

### *TDR Probe Assemblies*

- 1) Two (2) 36" Low loss flexible system coax cable
- 2) Two (2) 18" Low loss flexible system coax cable
- 3) One (1) High Frequency Probe (Falltime not to exceed 60 psec)

### *Panel Mounting Fixture*

- 1) Movable Tooling Pins for multiple panel sizes
- 2) Board Support Pin Hole Grid System and movable spring pins

### *Guarding and Operator Access Area*

- 1) Robotic guarding/covers
- 2) Operator access door
- 3) Door interlock

### *TDR Instrumentation*

- 1) Tektronix DSA8200 High Speed Digital Sampling Oscilloscope
- 2) Tektronix 80E04 Sampling Head
- 3) Two (2) Meter Sampling Head Extension Cable
- 4) Sampling Head Mounting Bracket

### *Base Table*

- 1) Wheels: Four(4)
- 2) Electronic cabinet with door
- 3) Leveling legs: Four (4)

### *Electronics Assembly*

- 1) Discrete Digital Input/Output: 20
- 2) Emergency Stop Assemblies

## Software

### *Software Suit*

HFT-1500 System (one license)

- Full TDR test capabilities as listed above

HFT Report Writer (unlimited site license)

- Data filtering (date, operator, customer, PN#, Order#, Pass/Fail, etc)
- Sort and Display by Layer number or Serial Number
- Export to MSExcel, Adobe Acrobat, etc.
- Display full statistics, histograms, and Out-of-Center reports

TDR Waveform Viewer (unlimited license)

- Off-line viewing of captured TDR Waveforms
- Allows easy selection of impedance measurement zone.
- Displays end and midpoint VIA affects.
- Dynamic cursor provides readout of impedance along entire trace.
- Creates printouts for documentation purposes.

HFT CAM Importer (unlimited site license)

- Automatic generation of Test Program thru importation of IPC data
- Eliminates loss test time due to utilization of test equipment to generate test programs

### *Capabilities*

Single-ended TDR Measurements

True Differential TDR Measurements

High Frequency Data Collected

- Impedance
- Propagation Delay
- Propagation Velocity
- Effective Er (Dielectric Constant)
- Interconnect Bandwidth
- TDR Waveform capture

IPC TM-650 2.5.5.7 Test Standard Compliant

Simplified Data Entry Screens for Test Program Generation

Automatic Test Program Generation and CAM Download

Data storage compatibility with Accu-Prober System

Extensive Test Report Generation (including Histograms and Out-of-Center reports)

Reporting of Impedance, Delay and Bandwidth for both sides of Differential pair

Programmable Threshold for Prop Delay Measurements

Selective CI Test Results Verification

Capability for automated system calibration procedure

Capability for automated system verification procedure for impedance and prop delay

Operational Event Logging

Interface to Tektronix's DSA8200

### *Support*

Site Installation and full site inspection

Operations and Maintenance Training (at installation)

Operations and Maintenance Manuals

Application Engineering Assistance (through warranty period)  
Preventative Maintenance Site Visit (twice within warranty period)

## System Specifications

Maximum Panel Size: 24" x 18" (610mm x 457mm)

Probe Rate: 12-60 tests per minute (dependent on parameters being measured)

System Probing Area:

X-axis:	23.4" (594mm)
Y-axis:	17.5" (444mm)

TDR Instrumentation Interface:  
Tektronix DSA8200 with 80E04 TDR Sampling Head Module

Measurement Accuracy:

Standard Deviation:	0.05 Ohms
Minimum Measured Trace Length:	0.5"
Propagation Delay:	4 psec

### *Installation Requirements*

#### Electric

Voltage: 120 VAC Single Phase  
Recommended External Circuit Breaker: 20 Amps  
Frequency: 50/60 Hz

#### Operating Environment

Temperature: 5° C to 40°C (41 to 104°F)  
Relative Humidity: 5 to 90% noncondensing  
Pollution degree: 2 (per IEC 1131-2/EN 61131-2)

#### Floor space

Machine Size: 42" x 40"  
System weight: Approx. 1000 Lbs.

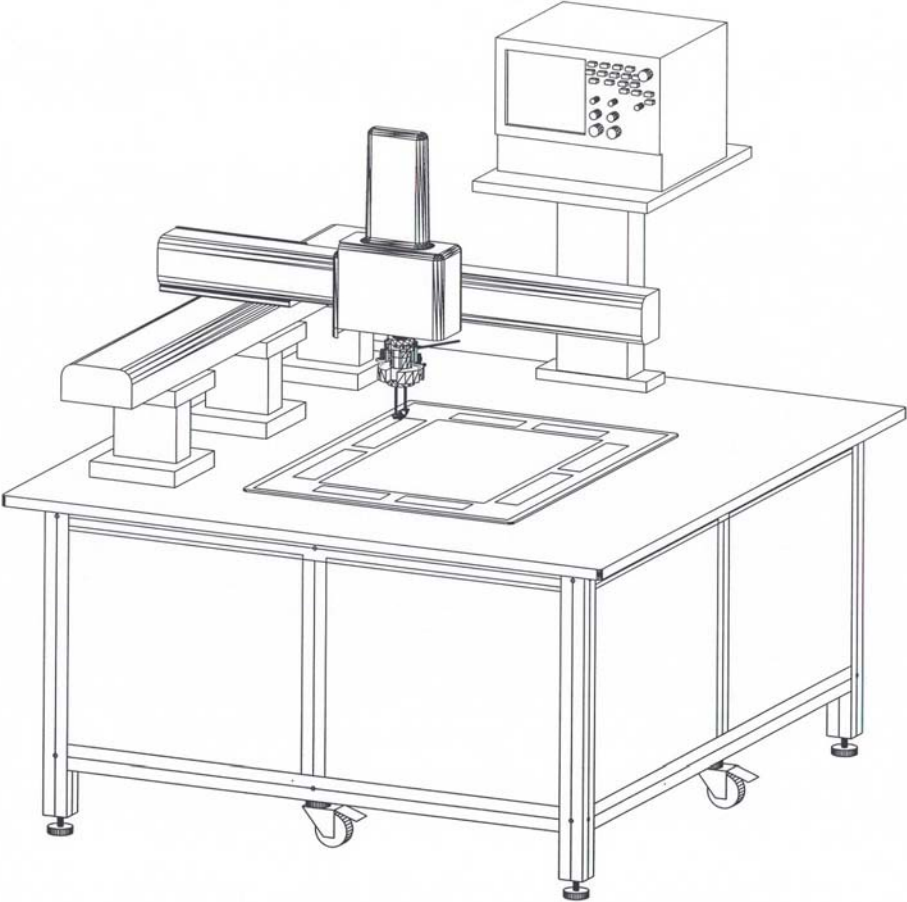

Figure 1: HFT-1500 Automated High Frequency Test System

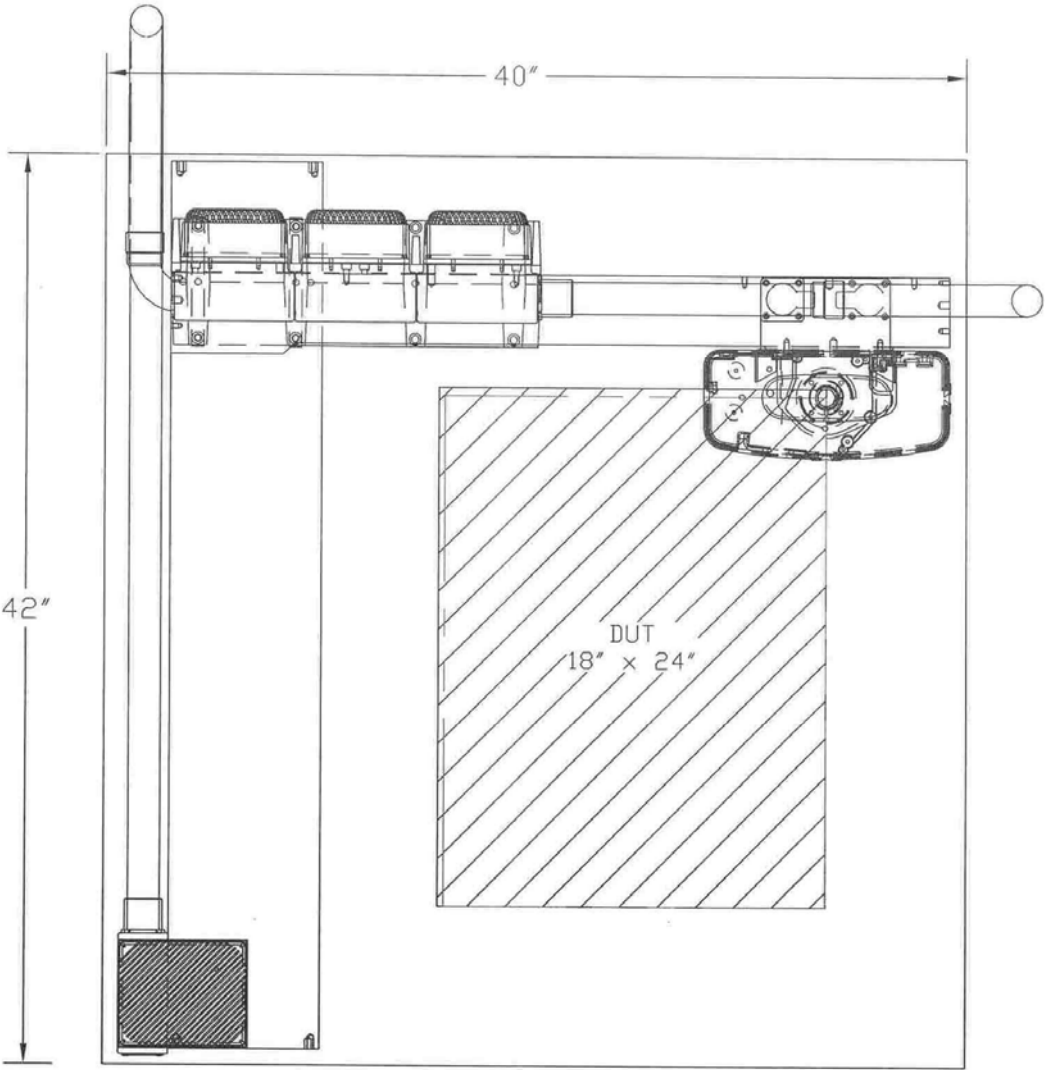

Figure 2: HFT-1500 Top View